

# MODEL ROCKETS.US Super CENTAURI

## Assembly Instructions

### Parts Included:

- 1 Nose Cone
- 1 Body Tube
- 1 Payload Tube
- 3 Laser Cut Balsa Fins
- 1 Thrust Ring
- 1 Motor Tube
- 2 Launch Lugs
- 1 Motor Hook
- 2 Centering Rings
- 1 Coupler
- 2 Bulkheads
- 1 Screw Eye
- 1 Kevlar Shock Cord (yellow)
- 1 Elastic Shock Cord (white)
- 1 Parachute Kit
- 1 Decal Sheet

### Materials (not Included):

- Scissors
- Ruler
- Yellow Wood or White Glue
- Sanding Sealer
- Paint Brush
- Sandpaper (#240 grit)
- Gloss Spray Paint
- Primer Spray Paint
- Masking Tape



## Motor Mount and Shock Cord Assembly

**Step 1** – Tie a single knot at the end of the yellow kevlar shock cord.



**Step 2** – Insert the flat end of the metal motor hook into the pre-cut slot 1/4" from the end of the motor tube.

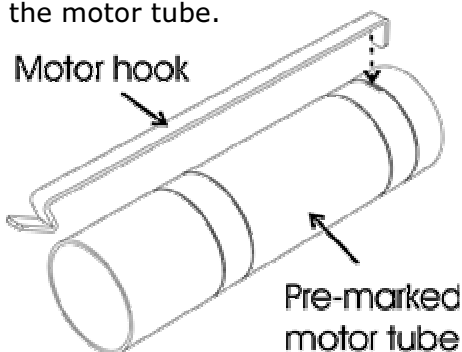

**Step 3** – Slightly expand the inside of the 2 larger centering rings by twisting on the end of the nose cone. **Important:** Don't expand the smaller trust ring.

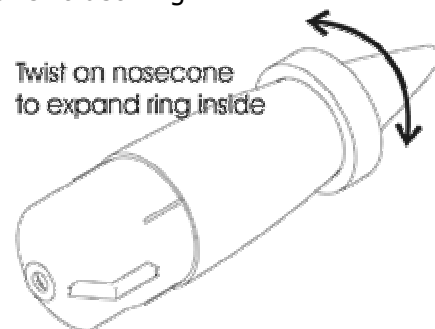

**Step 4** – While holding the motor hook in the slot, apply glue around the motor tube between the marks. Push the expanded end of the centering rings over the motor hook with the knotted end of the kevlar shock cord

through the rear centering ring until the rings are between the marks on the motor tube.

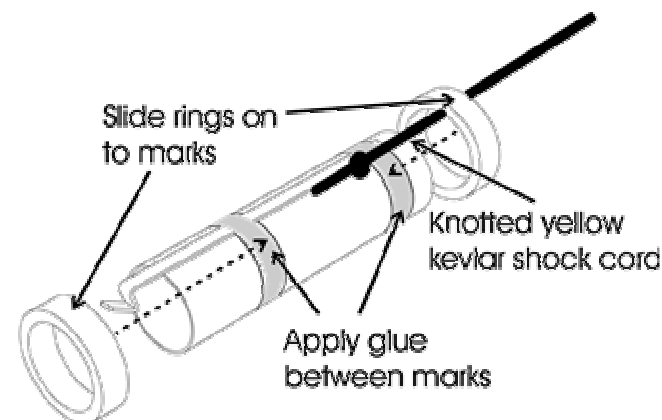

**Step 5** – Apply glue around the outside of the thrust ring and insert into the motor tube at the end where the motor hook is inserted. Push in until against the motor hook and flush with the end of the motor tube.

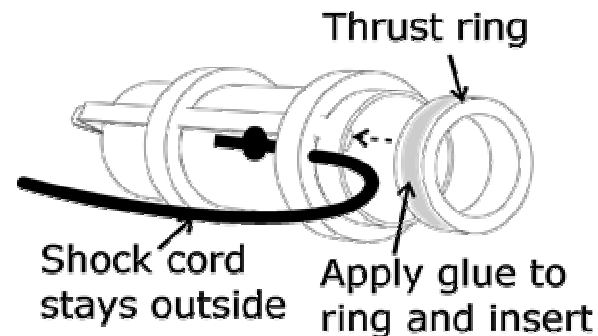

**Step 6** – Loop the yellow kevlar shock cord through the thrust ring end of the motor tube. The rings should be positioned as shown.

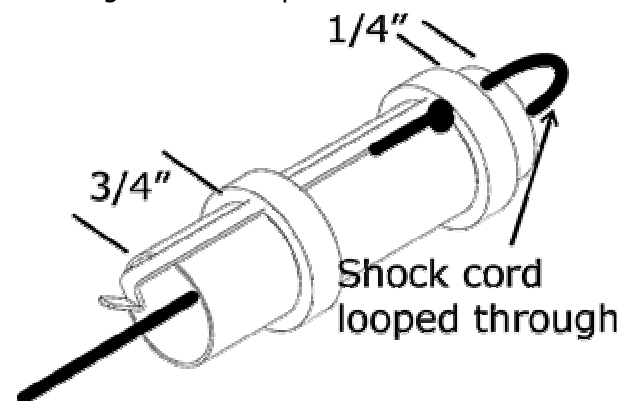

## Inserting and Attaching the Motor Mount

**Step 1** – Using a Q-tip or your little finger apply glue liberally around the inside end of the body tube about ½” in at the end of the slots for the fins.

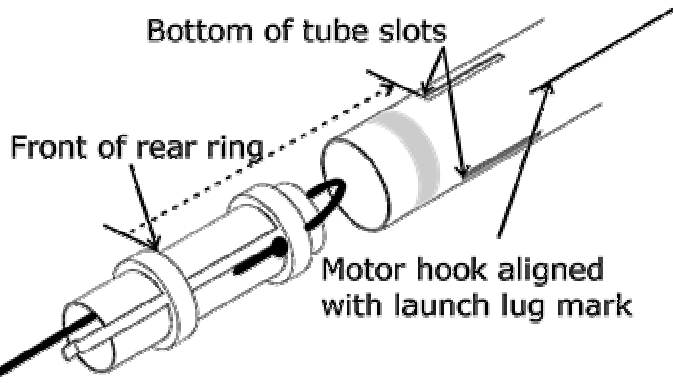

**Important:** Do the following motor mount insertion in one move. Do not stop until the motor mount is in the correct position.

**Step 2** – Insert the motor mount and push in until the bottom of the motor tube is flush with or slightly below the bottom of the body tube. Both rings should be clear of the fin slots. Clean any residue glue from the slots and set aside to dry.

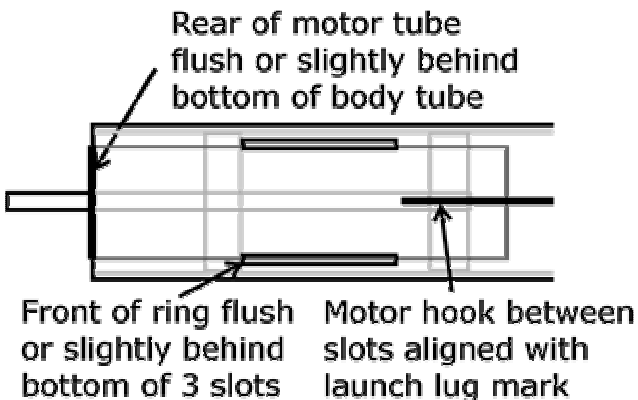

## Preparing and Attaching the Fins

**Step 1** – Press or break out the balsa fins from the laser cut sheet.

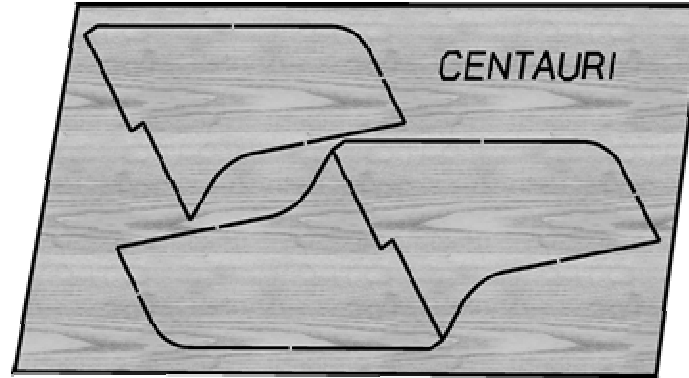

**Step 2** – Sand the leading edge and the tip of each fin round. Leave the root of the fin where it inserts and attaches to the body tube square.

Sand leading edge of fins and tip round

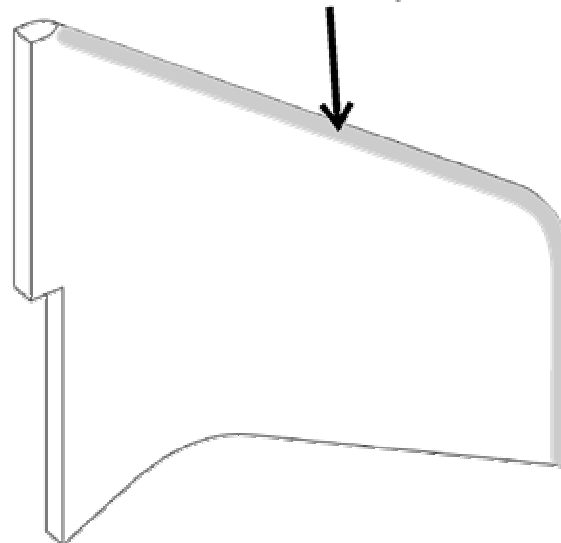

**Step 3** – Apply a bead of glue to the root edge on each fin and insert the root tab of each fin into the fin slots on the body tube. The front root edge of the fins should glue against the motor tube inside and the rear root edge against the body tube outside.

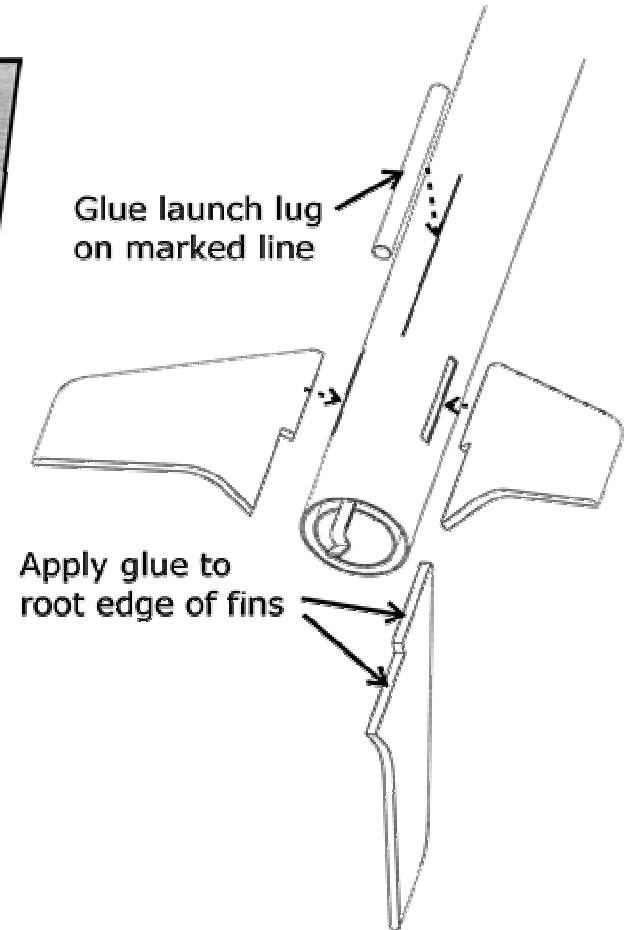

**Step 4** – Apply a thin bead of glue along the length of the launch lug and attach to the body tube where the launch lug line is marked. Allow to dry for ½ hour or more.

**Important:** Keep the fins and the launch lug aligned while drying. Make sure the fins are aligned 120 degrees apart. Use the fin guide on the next page to align the fins while drying.

## Preparing and Attaching the Fins Continued...

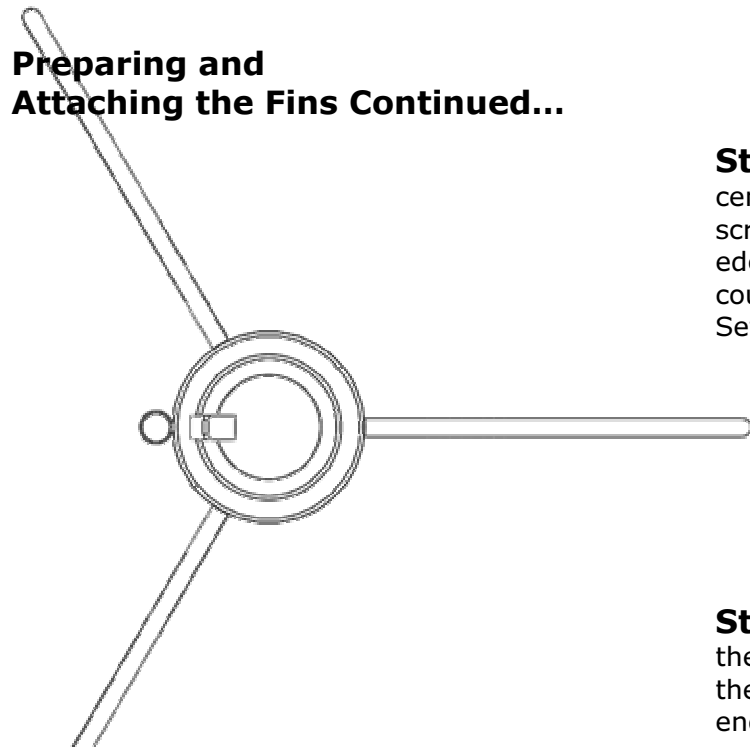

**Step 5** – After the fins and launch lug have dried, apply a thin layer of glue between the body tube and the fins, and the body tube and launch lug with your finger to create a fillet that will strengthen the fins and launch lugs. Set aside to dry. Check the fin alignment to make sure they are 120 degrees apart while drying.

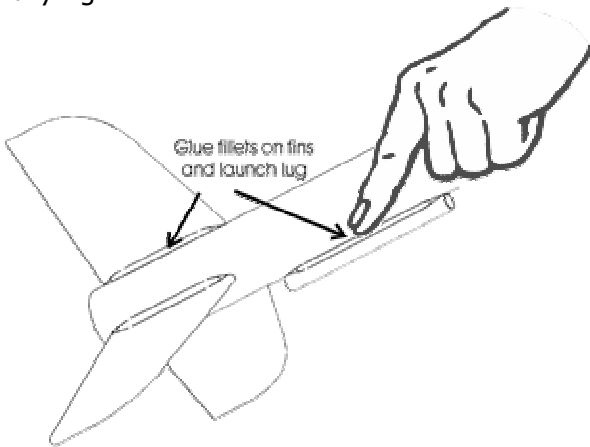

## Assembling the Payload Section

**Step 1** – Apply glue to the hole in the center of the plywood bulkhead. Screw in the screw eye in the same hole. Apply glue to the edge of the bulkhead and insert into the coupler until flush with the end of the coupler. Set aside to dry.

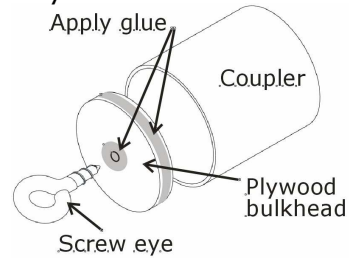

**Step 2** – Apply a thin bead of glue around the inside edge of the payload tube and insert the bulkhead assembly until it is 1/2" from the end of the payload tube.

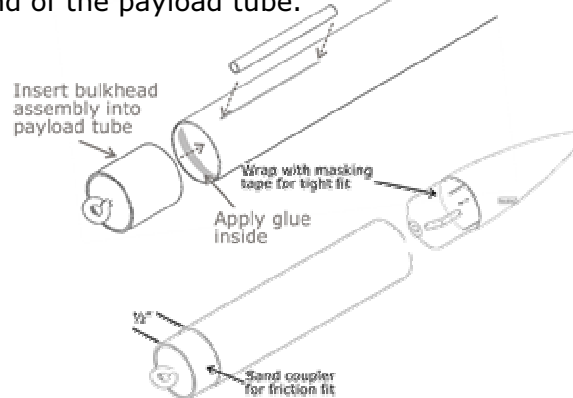

**Step 3** – Apply a thin bead of glue along the length of the launch lug and attach to the body tube where the launch lug line is marked. Allow to dry. After it is dry, fillet the launch lug on the payload section.

**Step 4** – Check the fit of the coupler in the body tube. If necessary, sand with #240 grit sandpaper (usually not necessary) for a friction fit. Wrap masking tape around the shoulder of the nose cone for a snug fit in the payload tube.

## Attaching the Parachute and Payload Section

**Step 1** – Feed the yellow kevlar shock cord through the bottom of the body tube and pull out through the top.

**Step 2** – Tie both the white elastic shock cord and the yellow kevlar shock cord together with a single looping knot and pull both shock cords apart to tighten the knot.

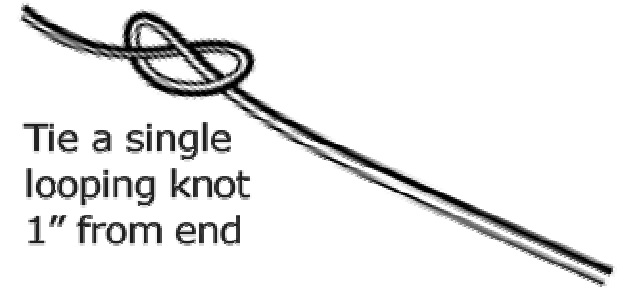

**Step 3** – Remove the parachute parts from the parachute kit bag and follow the assembly instructions printed on the parachute sheet.

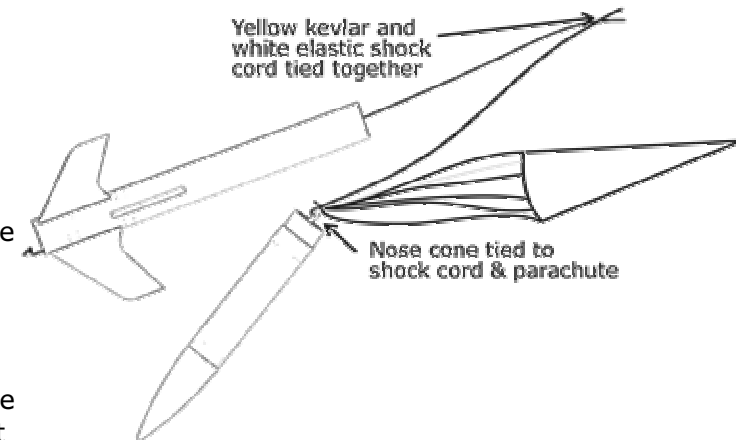

**Step 4** – Tie the end of the parachute shroud lines to the screw eye on the payload section.

## Finishing Your Rocket (Optional)

**Step 1** – Using 240 grit sandpaper, sand the nose cone so that the paint will stick.

**Step 2** – Roll up a sheet of paper and insert into the bottom of the rocket body tube to hold your rocket, apply a thin coat of flat white or gray primer spray enamel to the whole rocket using even back and forth movements. Let the primer dry and sand using 240 grit sandpaper. Re-coat and sand as necessary.

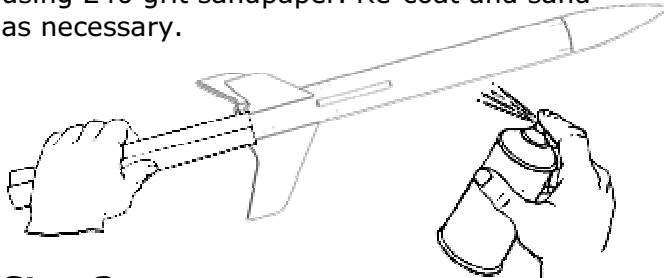

**Step 3** – Apply a first thin color coat of gloss spray enamel to the whole rocket using even back and forth movements. Let the first coat tack up for a few minutes. Then follow up with a heavier coat. Do not coat too heavily or the paint will sag. The best results are obtained when the color coat is just thick enough to gloss. If additional coats are needed to cover the primer with full color, re-apply after the color coat has tacked up within the first hour or wait 24 hours until the color coat is completely dry. Let the final coat dry for 24 hours.

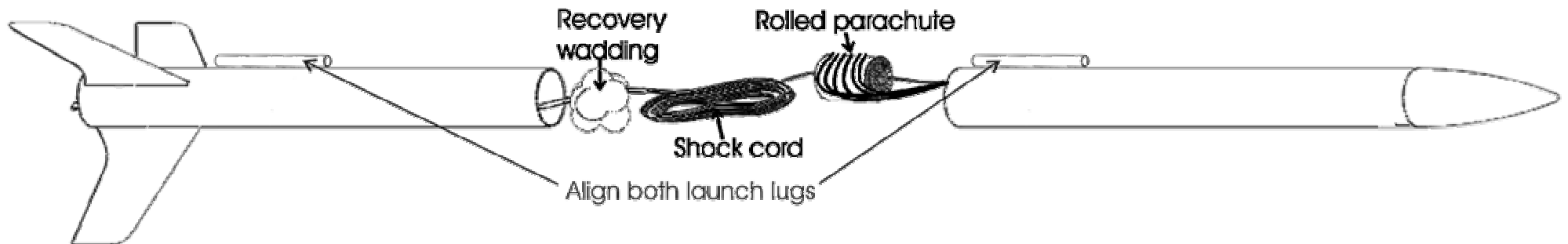

**Step 4** – Remove the pressure sensitive decals from the backing paper and apply to the fins and body tube. Use the picture on the cover of this manual for a guide to decal placement.

## Flying Your Rocket

### Flight checklist:

- Model Rocket
- Launch Pad & Controller w/Batteries
- Recovery Wadding
- Model Rocket Motors and Igniters

Recommended Motors for the CENTAURI rocket are A8-3, A6-4, B4-4, B6-4, C6-5 & C6-7

**Step 1** – Insert 2-3 crumpled recovery wadding sheets into the body tube and the shock cord after the recovery wadding.

**Step 2** – Fold the parachute and roll up small enough to fit into the rocket body tube. Insert the parachute into the rocket body tube and insert the payload section and align the launch lug of the payload section with the launch lug on the body tube to complete the recovery assembly.

**Step 3** – Install model rocket motor igniter according manufacturers recommended procedure.

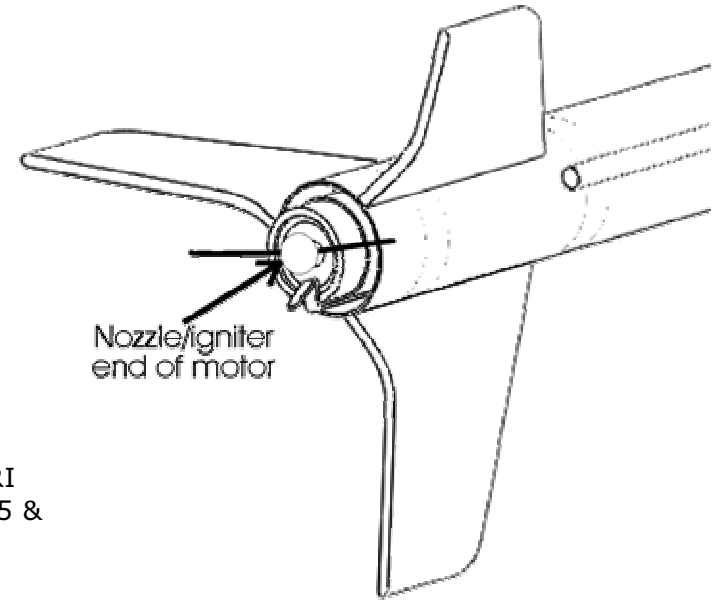

**Step 4** – Insert the rocket motor with the nozzle/igniter end facing the rear of the rocket. The motor should clip into place with the motor hook retaining the motor.

**IMPORTANT:** FOLLOW THE N.A.R. SAFETY CODE REGARDING LAUNCHING AND THE USE OF MODEL ROCKET MOTORS