

## Flying Your Rocket

### Recommended Motors:

24mm C11-3, D12-5  
24mm Single Use E15-7, E30-7  
24mm RMS D9-4, D15-4, E18-7, E28-7, F12-5, F24-7, F39-6

**Step 1** – Insert several crumpled sheets of recovery wadding into the body tube and the folded shock cord after the recovery wadding.

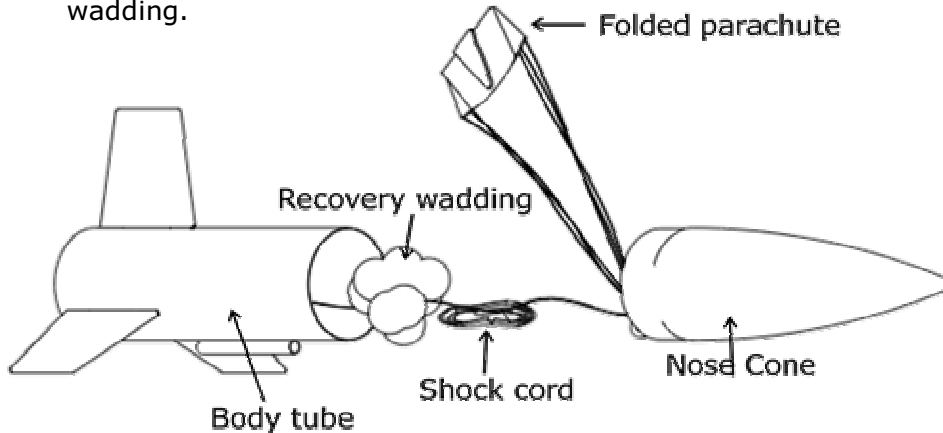

**Step 4** – Fold the parachute 4 times and roll the parachute lines over the folded parachute, insert into the rocket body tube, then insert the nose cone to complete the recovery assembly.

**Step 5** – Install model rocket motor igniter according to manufacturers recommended procedure.

**Step 6** – Insert the rocket motor with the nozzle/igniter end facing the rear of the rocket.

**IMPORTANT:** FOLLOW THE N.A.R. SAFETY CODE REGARDING LAUNCHING AND THE USE OF MODEL ROCKET MOTORS

*MODELROCKETS.US*

# BLOBBRO

## Assembly Instructions

### Parts Included:

- 1 Nose Cone
- 1 Airframe Tube
- 3 Laser Cut Lite-Ply Fins
- 1 Motor Block
- 1 MotorTube
- 1 Motor Hook
- 2 Laser Cut Lite-Ply Centering Rings
- 1 Launch Lug 3" Long
- 1 Kevlar Shock Cord (yellow)
- 1 Elastic Shock Cord
- 1 18" Nylon Parachute (color varies)
- 1 Decal Sheet

### Materials Needed (not Included):

- Yellow Wood Glue or Epoxy
- Sanding Sealer
- Paint Brush
- Sandpaper (#240 grit)
- Gloss Yellow Spray Paint (enamel)
- Primer Spray Paint (enamel)
- Masking Tape

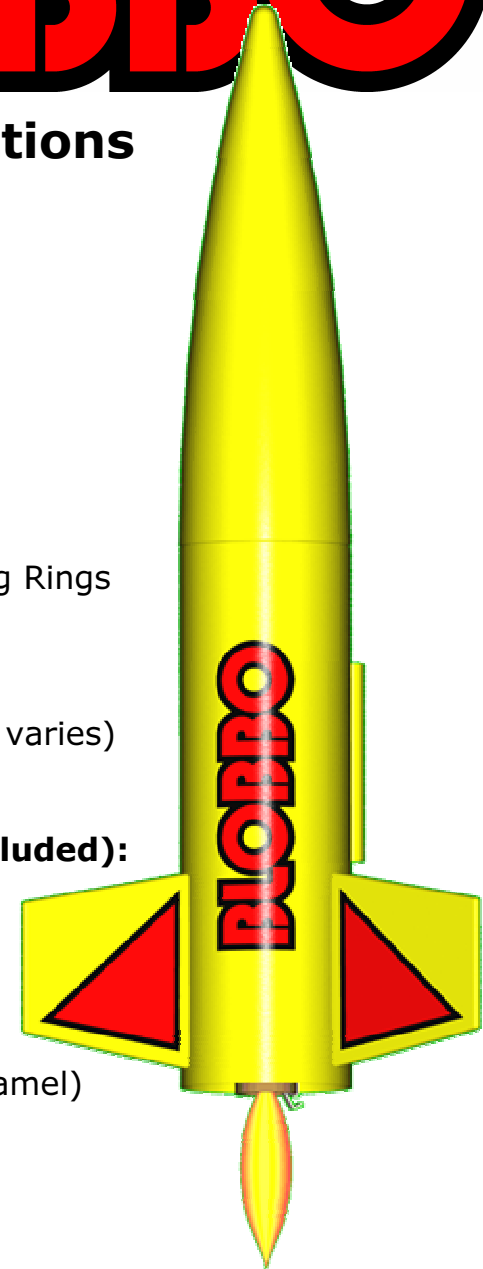

## Motor Mount and Shock Cord Assembly

**Step 1** – Tie the end of the elastic shock cord to the kevlar shock cord.

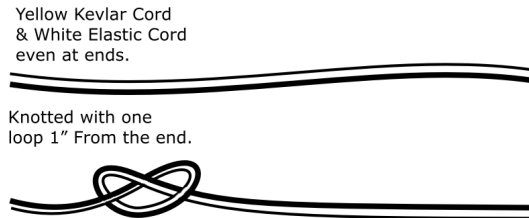

**Step 2** – Tie a single knot in the end of the Kevlar shock cord opposite the end the elastic shock cord is attached to.

**Step 3** – Mark the motor tube  $\frac{1}{4}$ " from both ends and slice a slot on at the  $\frac{1}{4}$ " mark for the motor hook. Apply glue to the middle of the motor hook and attach to the tube with the end of the motor hook in the slot. Wrap some masking tape around the tube in the middle to reinforce the motor hook.

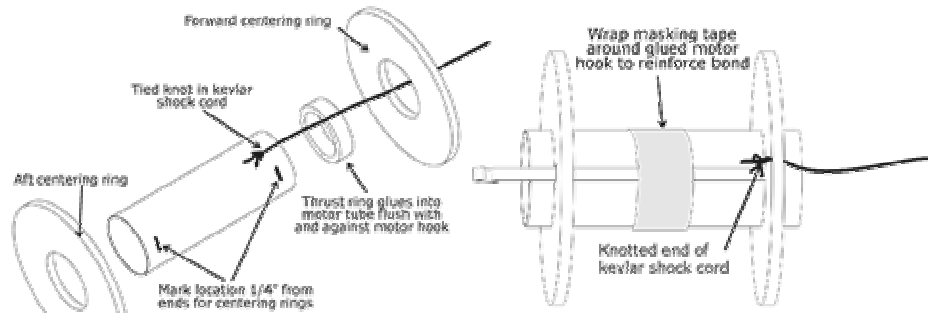

**Step 4** – Glue the thrust ring in the end forward end so that it is against the motor hook and flush with the end of the motor tube.

**Step 5** – Apply glue around the outside of the motor tube at forward end and place the single knotted end of the kevlar shock cord against the motor tube. Slide the forward centering ring with the inside notch over the Kevlar shock cord and slide to the  $\frac{1}{4}$ " mark. The forward centering ring has a notch on the inside that should be over the kevlar shock cord and the knot will prevent it from sliding out of the motor mount. Apply glue around the motor tube at the aft end and slide the aft centering ring to the  $\frac{1}{4}$ " mark. The slot in the aft centering ring should line up with the motor hook so that the motor hook can move up and down in the slot.

## Finishing Your Rocket

**Step 1** – Using 240 grit sandpaper, sand the fins of the rocket lightly to remove loose grain and sand the nose cone so that the paint will stick.

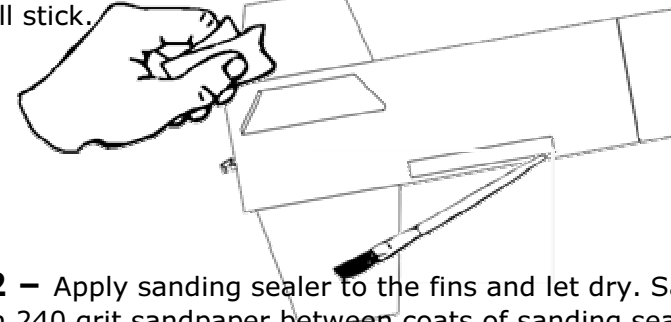

**Step 2** – Apply sanding sealer to the fins and let dry. Sand the fins with 240 grit sandpaper between coats of sanding sealer. Repeat this process until the fins are smooth and the balsa grain is filled.

**Step 4** – Insert a dowel into the bottom of the rocket body tube to hold your rocket, apply a thin coat of flat white or gray primer spray enamel to the whole rocket using even back and forth movements. Let the primer dry and sand using 240 grit sandpaper. Re-coat and sand as necessary.

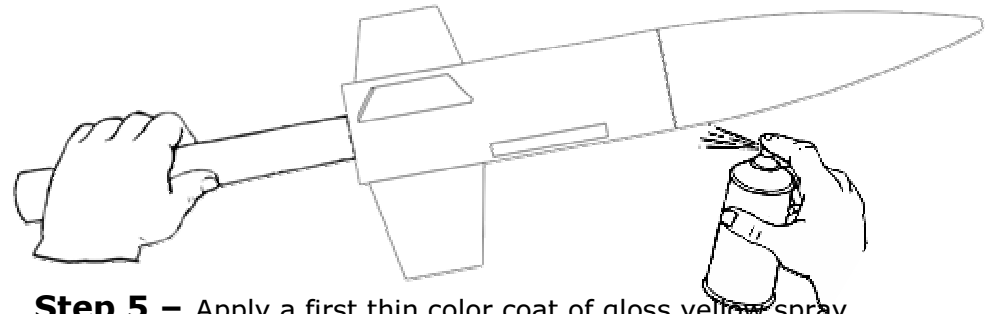

**Step 5** – Apply a first thin color coat of gloss yellow spray enamel to the whole rocket using even back and forth movements. Let the first coat tack up for a few minutes. Then follow up with a heavier coat. Do not coat too heavily or the paint will sag. The best results are obtained when the color coat is just thick enough to gloss. If additional coats are needed to cover the primer with full color, re-apply after the color coat has tacked up within the first hour or wait 24 hours until the color coat is completely dry.

**Step 6** – Remove the pressure sensitive decals from the backing paper and apply to the fins and body tube. Use the picture on the cover of this manual for a guide to decal placement.

## Attaching the Parachute and Nose Cone

**Step 1** – Tie the elastic shock cord to the nose cone with a double overhand knot.

**Step 2** – Tie the parachute to the nose cone with a double overhand knot.

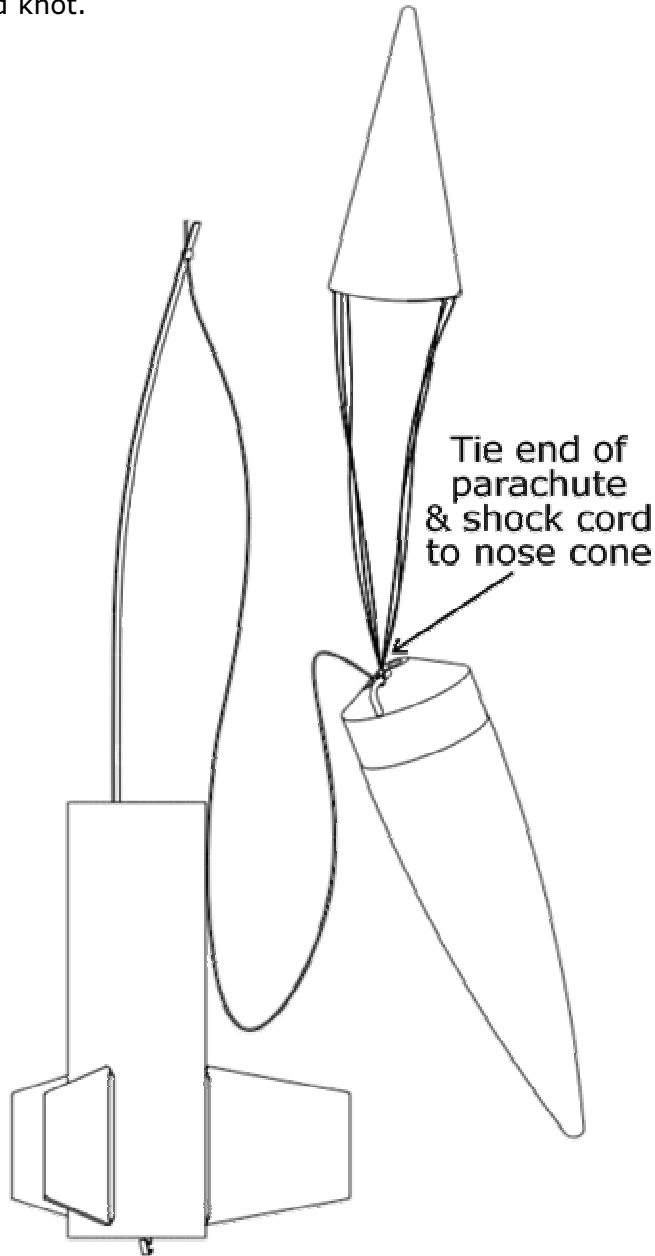

## Motor Mount Attachment

**Step 1** – Mark the inside of the airframe tube  $\frac{1}{2}$ " from the end with the 3 fin slots. Apply glue all around the inside end of the airframe tube about 1" in from the bottom end.

**Step 2** – Insert the motor mount and push in until the centering ring is at the  $\frac{1}{2}$ " mark on the inside of the tube. Make sure the motor hook is oriented on the same side as the launch lug location slot. Set aside to dry with the motor mount side of the airframe tube facing down.

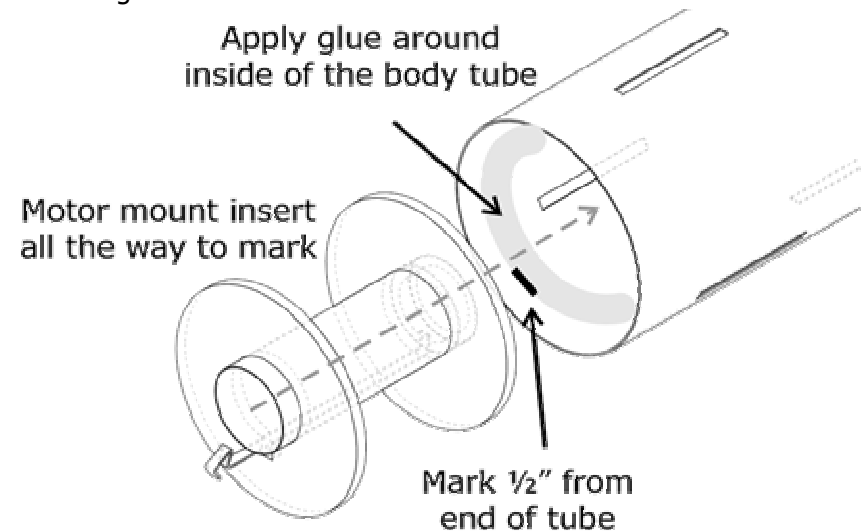

**Step 3** – Apply a glue fillet at the centering ring and body tube attachment joint. Set aside to dry with the motor mount side of the airframe tube facing up.

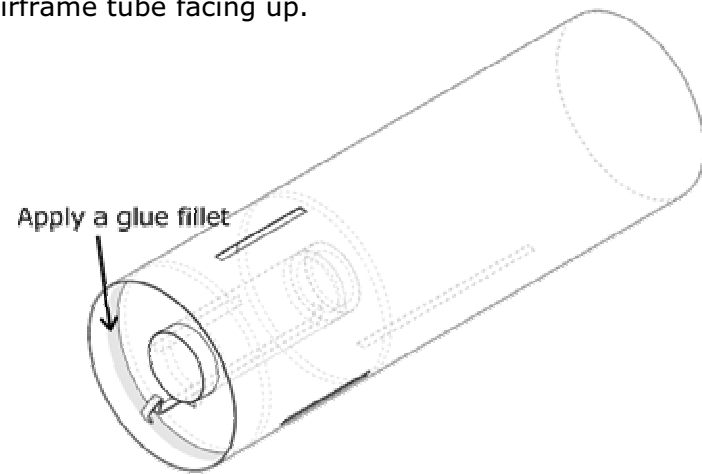

## Fins & Launch Lug Attachment

**Step 1** – Using 120 grit sandpaper, sand all 3 fins front edges and tips round. Then, using 220 grit sandpaper, sand the flat surfaces and edges smooth. Do not round the rear edges of the fins. However you can sand these smooth by placing the sandpaper on a table surface to sand the rear edges.

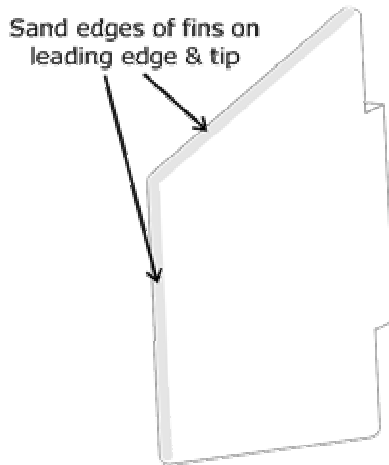

**Step 2** – Apply glue to the root edge and tab of each fin and place each fin into the fin slots near the bottom of the body tube.

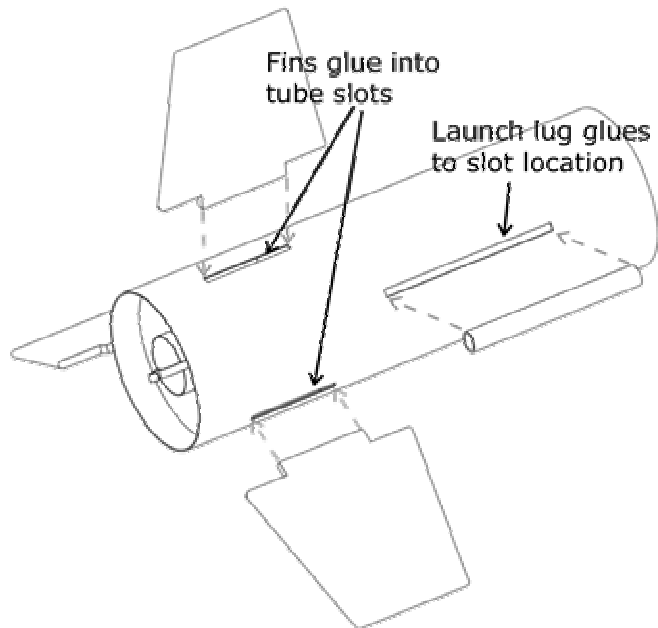

4

## Preparing and Attaching the Fins Cont...

**Step 3** – Keep the fins and the launch lug aligned while drying. Use the fin marking guide on the this page to make sure the fins are aligned 120 degrees apart.

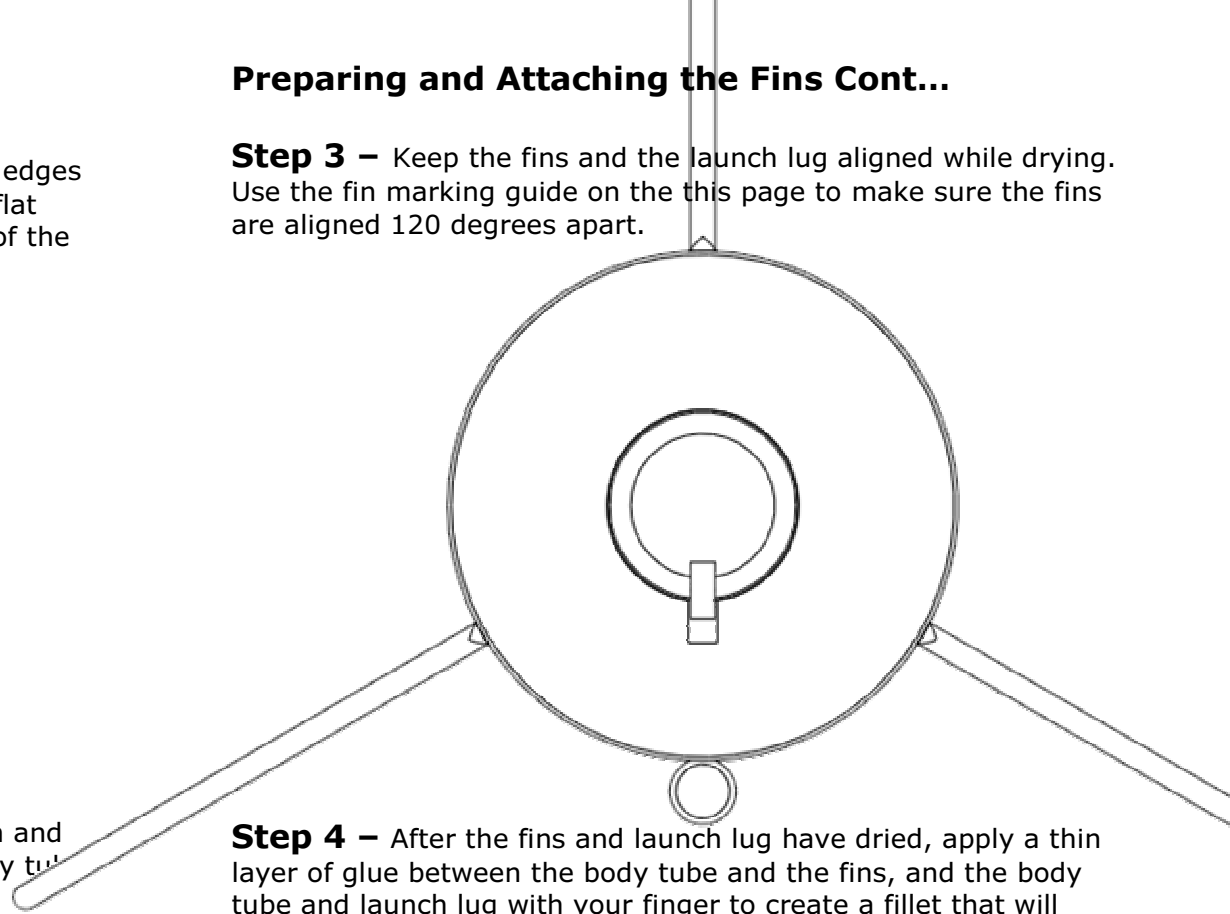

**Step 4** – After the fins and launch lug have dried, apply a thin layer of glue between the body tube and the fins, and the body tube and launch lug with your finger to create a fillet that will strengthen the fins and launch lugs. Set aside to dry. Check the fin alignment to make sure they are 120 degrees apart while drying. Use the fin marking guide to check alignment.

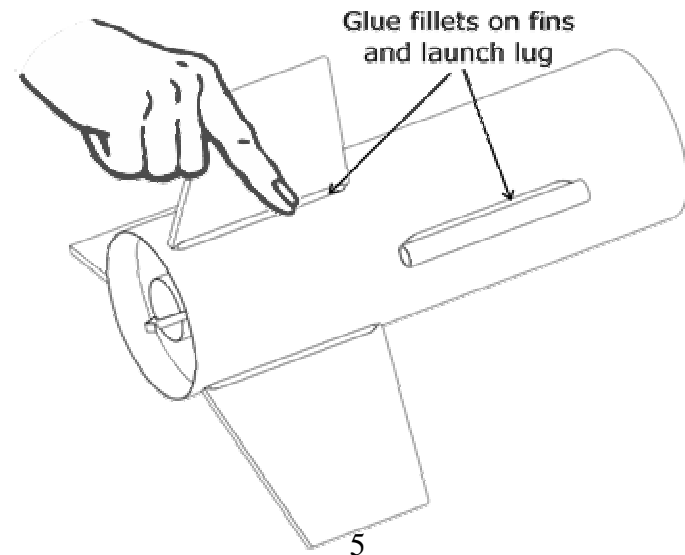

5