

ESTES
EDUCATOR™

www.esteseducator.com

GUIDE FOR TEACHERS AND YOUTH GROUP LEADERS

**A Guide to Introduce
Educators to the Benefits
of Estes® Model Rocketry**

**By John Carroll
Updated and edited
by Ann Grimm**



© 1992, 1999, 2002 Centuri Corporation.
All rights reserved.

THE ESTES EDUCATOR™ GUIDE FOR TEACHERS AND YOUTH GROUP LEADERS

This booklet will:

- A. Describe some of the benefits you and your students can derive from Estes® Model Rocketry.
- B. Introduce you, the educator, to Estes® Industries and our Educational Program.
- C. Describe the Estes® Product Line.
- D. Explain important facts about the model rocket engine, the heart of model rocketry.
- E. Detail the preparation and launch of your rocket.
- F. Acquaint you with laws and regulations pertaining to model rocketry.

“THINK ESTES® FOR ALL OF YOUR MODEL ROCKET NEEDS”

A. HOW ESTES® MODEL ROCKETRY BENEFITS YOU AND YOUR STUDENTS

Welcome to Estes® Model Rocketry! This guide will point you in the right direction and familiarize you with Estes® products so that your experiences with your students will be satisfying and rewarding.

Many positive qualities have been associated with the use of model rocketry in the classroom. Educators describe it as an “exciting”, “motivational” and “high energy” teaching tool. Thousands of teachers successfully use Estes® rockets as part of their curricula every year. Over the years these teachers have become members of the Estes® “family”, staying in touch with us and sharing their experiences.

Apart from the anticipation that builds during their rocketry units and witnessing their students’ enthusiasm on “launch day”, teachers have expressed many reasons why they use Estes® products from year to year. With model rocketry, you will easily be able to:

- Provide a high energy “catalyst” that combines units in science with developments in space - bring space into your classroom.
- Provide a flexible medium that will engage your students’ creativity in several areas including: social studies, reading, crafts, technology and science.
- Introduce an affordable “technology in miniature” that will acquaint your students with technical concepts, terms and techniques at a time when the lack of technical literacy has become a major educational concern.
- Foster a close co-investigator relationship between you and your students, one that usually grows from year to year.
- Create interest in your students to pursue engineering and science studies, perhaps to a professional level.
- Provide an easy to use framework to develop your students’ ability to properly design, conduct and report experimental investigations.
- Make unique and captivating learning opportunities for those students who have become disinterested in traditional school activities.
- Offer practical opportunities for learning disabled students.
- Accurately make assessments as to your students progress through the unit.
- Expand your curriculum from basic introduction through more advanced topics.
- Provide an excellent culmination of activities in the spring by staging a “Launch Day”.
- Involve community and media during launch day and give your class a chance to shine!
- Experience the sense of accomplishment that develops as the students progress from an assemblage of parts and ideas to a successfully flying model rocket.

People have often said they receive greater benefits as teachers than their kids do as students. Although this is probably true of any teaching experience, model rocketry does provide many solid benefits for your students - benefits they may not receive from any other experience while they are in school. Some of these are:

- Development of real connections between theory and hands-on applications in science, math and technology.
- Encouragement to actively play a role in ALL phases of rocket construction, launch and experiment development.
- Development of greater fine-motor skills.
- Improvement of spatial relations and conceptual thinking skills.
- An opportunity to demonstrate expertise and knowledge before one's instructors and peers.
- To gain experience in designing, conducting and reporting basic experimental investigations.
- Enhancement of self-image through successful accomplishments.
- Improvement of cooperative skills in group activities.
- Development of greater awareness for safety and attention to detail.
- Having a memorable and positive experience during the learning process.

B. INTRODUCTION TO OUR COMPANY AND OUR EDUCATIONAL PROGRAM

Estes® Industries

For over forty years Estes® Industries has been the world's leader in the manufacturing of reliable and high quality model rocket products. The need to provide an easy to use and exciting teaching aid for science awareness and education was the thrust behind Vern Estes' development of Estes® Industries back in 1958.

Since then, due mainly to the mass produced and extremely reliable model rocket engine technology he developed, over 300 million successful launches have occurred. From its inception, our qualities have made model rocketry a reliable and easy to use learning medium for instructors in all learning environments. These qualities are:

- 1.) Precisely manufactured, expendable solid propellant engines that are of proven design, tested and conform to strict performance parameters.

Figure 1

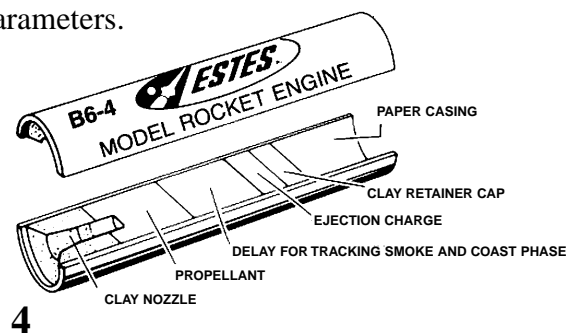

2.) Lightweight, non-metal rocket construction materials. Models are designed to absorb the energy of any impact by crushing.

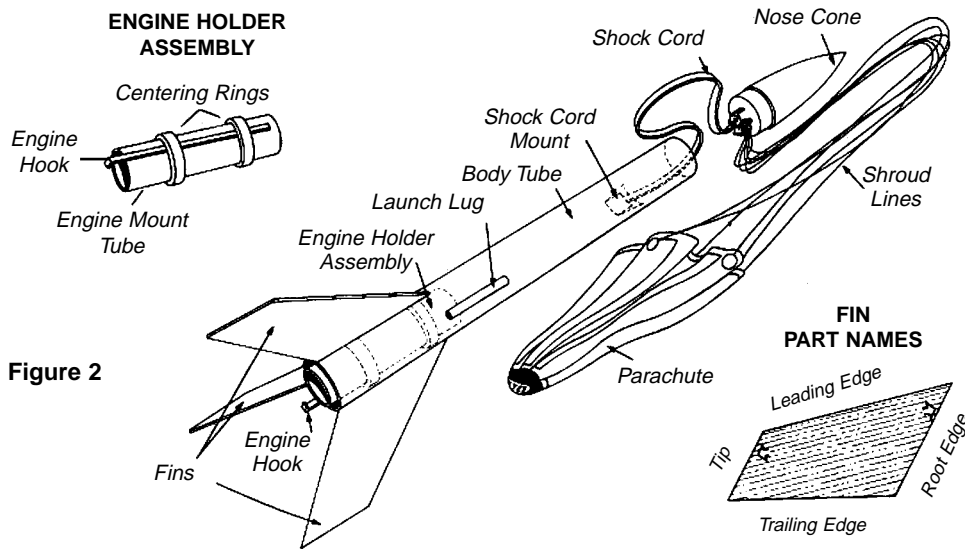

Figure 2

3.) Absolute control of the launch sequence through the use of an electrical launch controller, stable launch pad and electrical igniter.

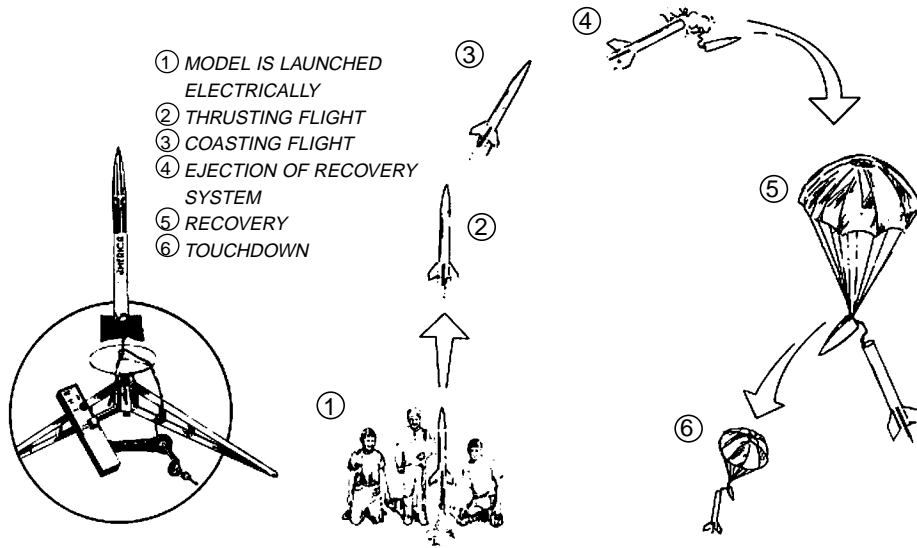

Figure 3

4.) Reliable recovery mechanisms to return the rocket safely to the ground for subsequent flights.

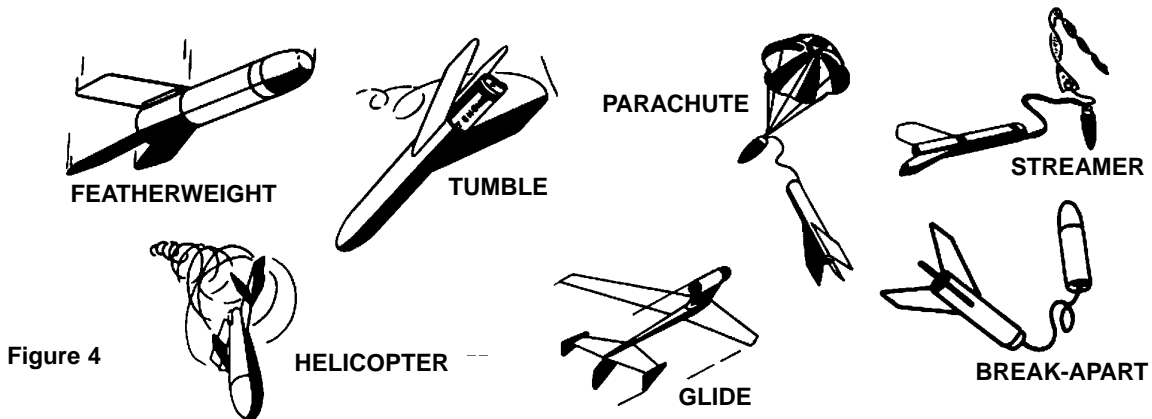

Figure 4

The Estes® Educational Program

Three foundations of the program are:

- 1.) To allow your students to discover fundamental principles of nature for themselves: Helping them in their academic progress by sparking critical thinking skills and better research and observation techniques.
- 2.) To ignite curiosity and creativity through inter-active exploration of the subject using model rockets as a focus.
- 3.) To provide an integrated resource of model rocket materials and the easy implementation of model rocketry as a useful classroom learning tool that will send your students' enthusiasm into orbit!

One of the greatest concerns to educators is how to bring to life subject materials so students will become enthusiastic about the subject and apply the experience across other curricula and to other parts of their lives. Merely reading and memorizing “subject matter” (being a “knowledge consumer”) is not an effective or interesting way to arouse a student's curiosity to learn. Retaining the flavor of learning, gaining new insight and having fun doing it is what model rocketry is about.

In exploring science and other curricula with model rocketry, students encounter experiences much like the great researchers they only read about in class. With your guidance, your students can design, conduct and modify their own experiments. They construct the very tools necessary to observe their experiment, collect data and verify their hypothesis.

In short, rocketry gives your students a unique way to become active participants (“producers of knowledge”) in the powerful process of science discovery in much the same way as great experimenters like Madame Curie and the Wright brothers in the past, and others who are continuing to do so today.

To assist you in developing and refining your students' learning skills, we at Estes® take pride in making available to you the materials necessary to introduce model rocketry as a viable teaching medium. The following diagram illustrates our educational program.

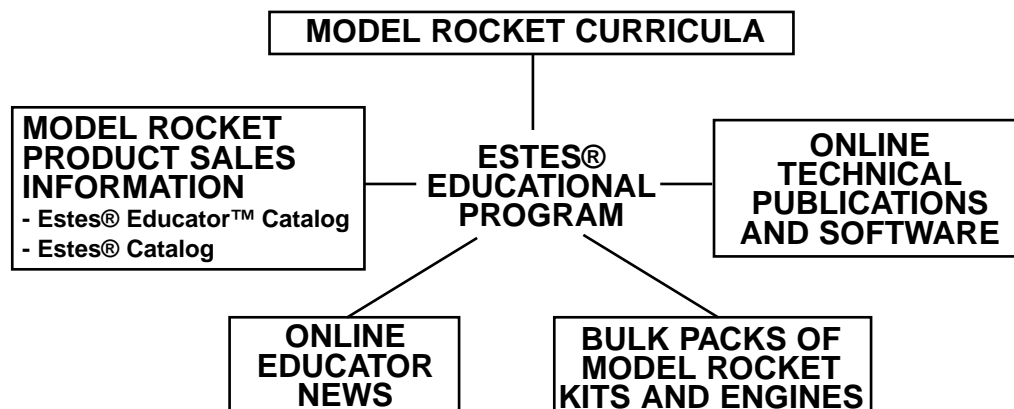

The Estes® Educational Program

MODEL ROCKET CURRICULA (ONLINE AT www.esteseducator.com) -

Science and Model Rockets, written by Sylvia Nolte, Ed. D

Assists educators with the introduction of model rocketry into the learning environment. Provides background information to the instructor on key topics and shows how to develop the subject in class.

Physics and Model Rockets, written by Sylvia Nolte, Ed. D

Mathematics and Model Rockets, written by Sylvia Nolte, Ed. D

Industrial Technology and Model Rockets, written by Richard Kalk, Ed. D
and Steve Wash

Aviation and Light Gliders, written by James H. Kranich, M.S., P.E.

Ignite the Imagination, written by Space Foundation staff members and Ann Grimm.

TECHNICAL PUBLICATIONS (ONLINE AT www.esteseducator.com) -

Written by Estes® staff and other professionals.

Designed to expand the basic knowledge gained through the curricula packages. Addresses those and other topics in greater detail. Material is presented in book and computer software form.

ESTES EDUCATOR™ NEWS (ONLINE AT www.esteseducator.com) -

Provides periodic updates on information about model rocketry topics, activities and news from other educators worldwide. **You are invited to submit articles and photos that can be used in the EEN. We encourage you to tell us how your experiences with Estes® rockets are going!**

MODEL ROCKET PRODUCTS -

We at Estes® would like to fulfill all of your model rocketry needs through a wide selection of kits, engines and accessories. Use our web sites and catalogs to familiarize yourself with Estes® products. We provide the highest quality products at the most reasonable prices for use in your classroom or youth group.

ESTES EDUCATOR™ BULK PACKS -

Our most popular educational rocket kits come in bulk packs. Each bulk pack box contains twelve rocket kits. The kits are individually bagged to assure a complete set of parts for each student. There are bulk pack rockets for beginners, intermediate and advanced students. Estes® model rocket engines come in bulk packs of twenty-four that also include igniters, igniter plugs and recovery wadding.

The Estes® educational program was developed as a complete program of educational materials that can be easily implemented and tailored to your specific needs. Treatment of the materials range from introductory level through more advanced studies. The materials you start with are updated periodically with the Estes Educator™ News to help you maintain a current and ongoing topic resource.

This brochure will describe four important topics, in addition to our education program, that will put Estes® model rocketry into perspective for you. These remaining topics are: information on Estes® rocketry products, some important facts about our engines, suggestions on how to conduct your launch and laws pertaining to model rocketry.

C. ESTES® MODEL ROCKET PRODUCT LINE

The Estes® model rocket product line consists of a complete range of rocket kit designs that will illustrate the principles that are studied as part of any model rocket unit.

As you review your Estes® catalog you will notice skill level descriptions that will assist in the selection of the appropriate rocket kits for you and/or your students to construct. The criteria that describes each skill level follows:

1. E2X® Kits (Almost Ready to Fly)

- Single stage rockets powered by a single engine no more powerful than a “D”
- Easy assembly - no modeling experience required
- Pre-aligned or molded plastic fin units featured on some kits
- Some measuring
- Simple gluing
- No painting
- Pressure sensitive decals

2. Skill Level 1 Kits

- Single stage rockets powered by a single engine no more powerful than a “D”
- Some modeling experience helpful
- Fin alignment attachment necessary
- Moderate measuring and cutting
- Gluing, sanding and sealing required
- Easy painting patterns
- Pressure sensitive decals

3. Skill Level 2 Kits

- Single or multi-stage rockets powered by engines no more powerful than an “E”
- Average to above average modeling experience required
- Fin construction and alignment may be complex
- Detailed measuring, cutting and gluing
- Sanding, sealing and varied painting schemes
- Unique design configurations

4. Skill Level 3 Kits

- Single or multi-stage rockets powered by engines no more powerful than an “E”
- Challenges the modeler’s skills
- Advanced wood, paper and plastic construction
- Precision measuring and cutting
- Uses several types of adhesives
- Sanding, sealing and complex painting schemes
- May have advanced payloads, i.e., electronic or other
- May be radio-controlled

5. Skill Level 4

- Master modeling skills are a must - recommended only for those 16 years of age and older
- Construction is extremely complex
- Unlimited propulsion options

6 “E” Engine Powered Kits

- Kits powered by Estes® “E” engines.
- For ages 18 and up. Adult supervision required for ages under 18
- Requires Estes® Porta-Pad® E Launch Pad and E™ Launch Controller
- Can also be flown on “D” engines
- Kits are Skill Levels 2, 3 and 4

Although some of your students may be comfortable with building most of our product line, we provide several introductory “easy-to-construct” (E2X®) rockets specifically for the classroom. These kits provide an excellent first time building experience. Given the limited time for construction in class, these rockets can be assembled quickly -- producing an attractive looking model. You can find these in the E2X® Rocket Kits section of our catalog.

In addition to our extensive line of model rocket kits, we also provide a complete line of spare parts and ground support equipment including:

- A full selection of rocket components by part number for new designs or replacement parts
- Tube Marking Guide
- Assorted hardware typically needed at the launch site
- Launch pads
- Launch controllers for remote electrical ignition of model rocket engines
- Altitude tracking equipment (ALTITRAK™)
- Recovery wadding
- Engines 1/4A through E in a variety of sizes and types (engine selection may vary)

Once the rockets have been constructed and the experiments or activities planned, you will need an electrical launch controller and launch pad to properly ignite the Estes® rocket engine and guide the rocket vertically into the air. Figure 5 illustrates the typical flight profile of a model rocket. After recovery, the expended engine is discarded and the rocket can be readied for another flight.

Before discussing the pre-flight preparation of your rocket, it is important to know a little about what has been called the heart of model rocketry, the model rocket engine. This device is one reason why this activity has enjoyed wide acceptance with teachers as a reliable and easy-to-use medium.

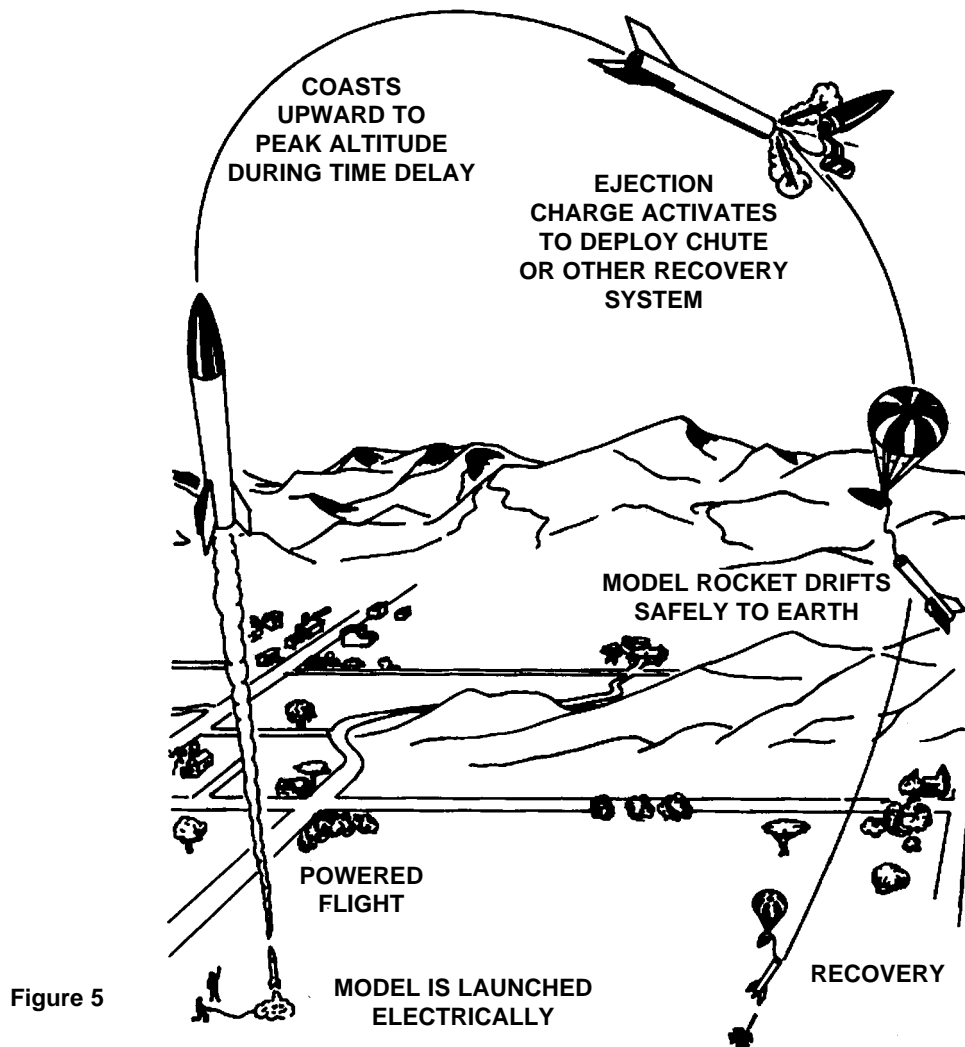

Figure 5

D. IMPORTANT FACTS ABOUT ESTES® MODEL ROCKET ENGINES

Due to their design as precisely manufactured packages of power with strictly engineered tolerances, Estes® engines are the standard in the industry. Some important features are:

- A reliable product throughout its 40+ year history, owing this outstanding record to experienced craftsmanship and engineering.
- Pre-manufactured propellants that are placed in their casings at the factory. The modeler does not have to handle or mix propellants, just insert the igniter in the engine and install the engine in the rocket.
- Expendable engines that are used once, then discarded. Attempting to reload these engines can be dangerous and is forbidden by regulations. Manufacturing of or tampering with propellants can be extremely dangerous and is against the model rocket safety code. Expendable model rocket engines have provided the foundation for model rocketry as an educational tool and hobby activity.
- Three percent of all Estes® engines are tested for reliability and adherence to performance standards. If standards are not met, the engines do not make it to market.

The following illustrations show the details of our engine. Figure 6 illustrates the Estes® color coding for use identification and the alphanumeric code for performance ratings. Recommended launch field sizes are shown in Figure 7 based on engine power usage.

ESTES® ENGINE CODING

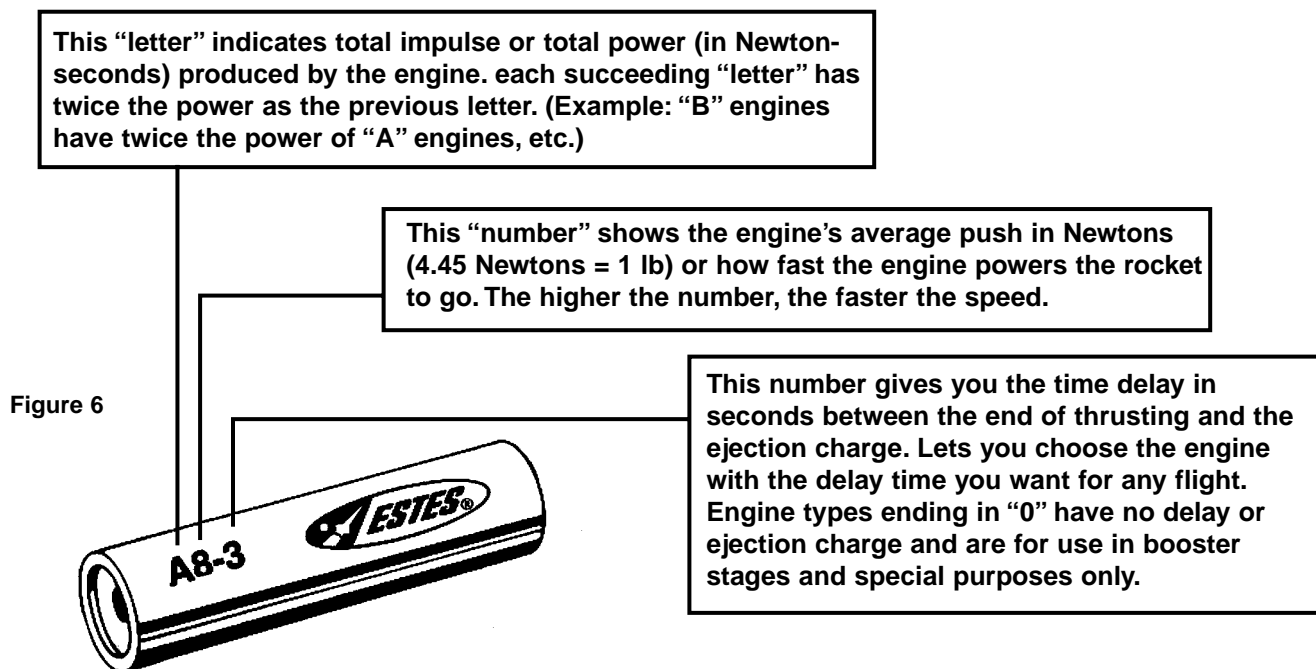

Estes® engines are color-coded for recommended use. GREEN engines are for use in single stage models; PURPLE engines for the upper stages of multi-stage rockets and very light single stage rockets; RED engines for all booster and intermediate states of multi-stage models. BLUE are “plugged” and recommended for special uses only.

LAUNCH SITE DIMENSIONS

Installed Total Impulse (Newton-seconds)	Equivalent Engine Type	Minimum Site Dimension (Feet) (Meters)	
0.00 - 1.25	1/4A & 1/2A	50	15
1.26 - 2.50	A	100	30
2.51 - 5.00	B	200	60
5.01 - 10.00	C	400	120
10.01 - 20.00	D	500	150
20.01 - 40.00	E	1000	300
40.01 - 80.00	F	1000	300
80.01 - 160.00	G	1000	300
160.01 - 320.00	2G	1500	450

Figure 7

TYPICAL TIME/THRUST CURVES ESTES® B6-4 MODEL ROCKET ENGINE

Figure 8 shows a cross section of a standard Estes® rocket engine and a time thrust curve used to plot the engine's performance. Comparing the force it exerts (vertical axis) versus the time over which it burns (horizontal axis) provided information about the engine's total impulse, average thrust and time delay.

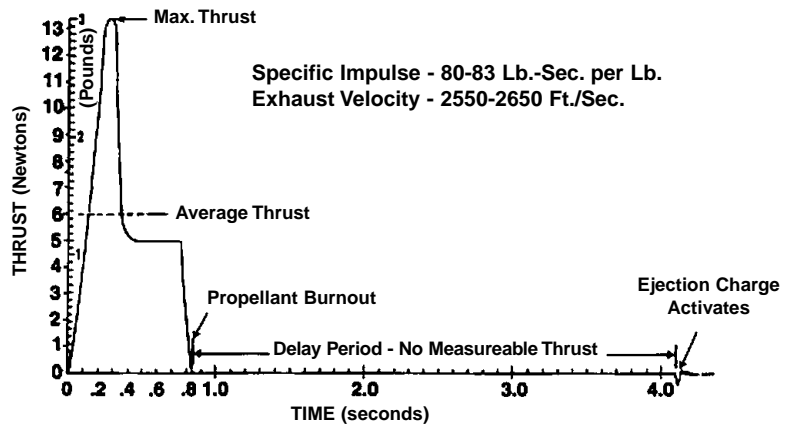
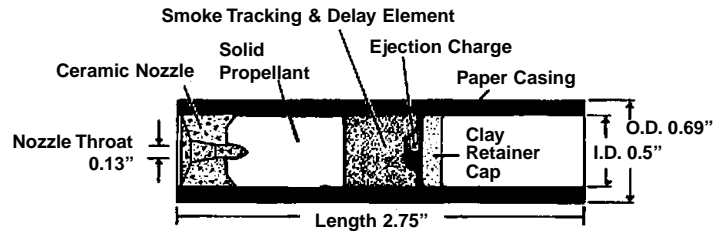

Figure 8

ESTES® MODEL ROCKET ENGINE FUNCTIONS

Graphic explanation of a model rocket engine's fundamental construction and functions.

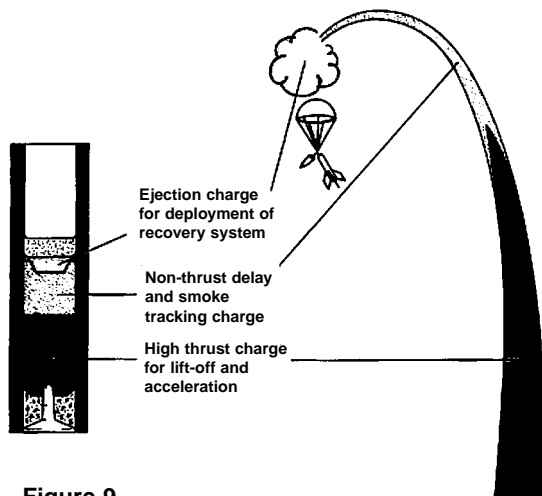

Figure 9

Figure 9 shows the internal structure of a typical Estes® model rocket engine and the function of each component during a typical flight.

NOTE: Use the Estes® Engine Chart in the Estes® catalog to determine your rocket's engine requirements and flight profiles.

WHERE TO FIND ESTES® PRODUCTS:

The Estes® materials that have been described above are available:

- Through your local Estes® hobby retailer including Estes Educator™ Authorized Retailers
- From school suppliers or wholesalers
- Direct from Estes® Industries

E. PREPARING YOUR ROCKET FOR FLIGHT AND SETTING UP YOUR LAUNCH ACTIVITY

Before launch day arrives, your students should already be familiar with preparing their rockets for flight. They should also know which tasks they will perform on the field. This will make launch day run much smoother for everyone and generate the atmosphere of a professionally conducted launch.

Follow the “Prepare Engine” instructions that are provided on the back of each rocket instruction sheet. The recovery wadding is inserted first if required by the design of your rocket. This material protects your recovery device from the heat generated during the ejection phase. After preparation of your rocket’s recovery device, the rocket engine may now be inserted in the engine mount. With the ceramic nozzle of the engine facing out, insert the electrical igniter all the way into the engine, then insert an igniter plug (this will assure the igniter is touching the propellant grain). Bend the igniter wires back and insert the engine into the rocket. See Figure 10.

Estes® model rockets should always be ignited with an electrical system using an electrical igniter. Igniter Plugs - U.S. Patent No. 5,410,966

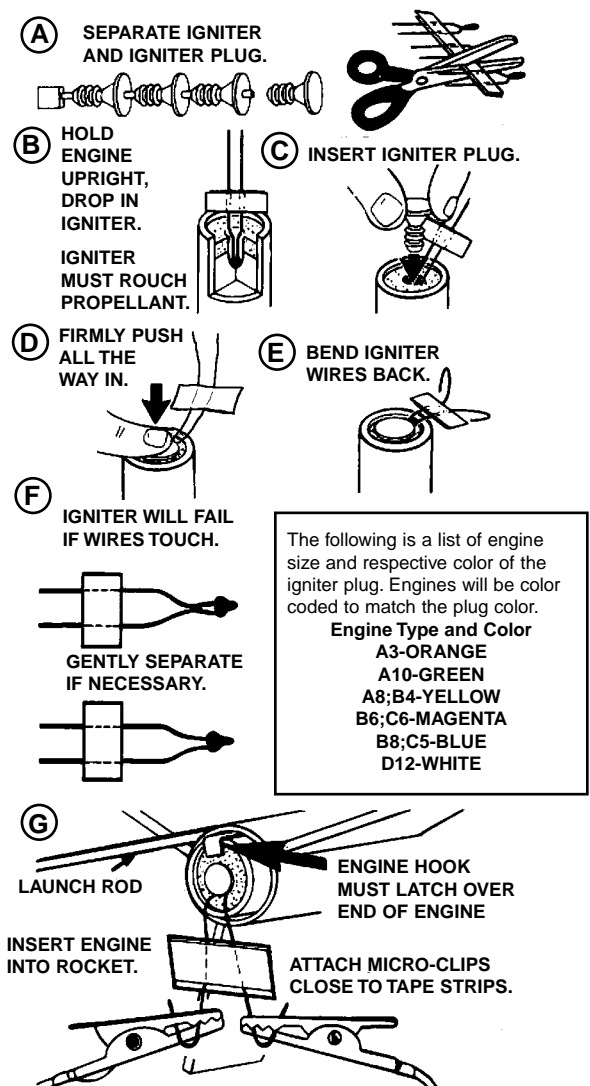

Figure 10

Follow the “Countdown and Launch” also on the back of the instruction sheet. Alert everyone the pad is active; proceed with an audible countdown and launch. Remove the safety key from the controller and replace the safety cap on the launch rod following each launch. It is a good idea to rehearse the launch and post launch sequence in the classroom prior to setting up on the field.

Now that you have the mechanics of handling and launching model rockets, organizing the actual launch and appointing positions of responsibility to the students is all that remains. To heighten the excitement of any launch, it is fun to appoint specific duties for everyone to perform. This increases the feeling of involvement for your students and enhances safety since everyone is aware of what is happening.

An organized launch day also demonstrates to the rest of your school or group that rocketry is fun and the people involved with it are serious about safety.

The following suggestions will help you conduct a successful class or group launch:

1. Review the National Association of Rocketry (NAR) Safety Code with your students.
Always follow this code.
2. Be sure each student is properly trained to perform his or her specific task prior to launch day.
3. In the event of a misfire, remove the safety key from the controller and wait one minute before disconnecting the micro-clips. Then remove the rocket and replace the igniter.
4. Only launch crewmembers, tracking teams and the person launching his or her rocket should be on the launch site.
5. Allow recovery of the rocket only by the recovery team or builder.
6. The altitudes to which the model rockets are launched should not be more than two to three times the width of the field which is available for launching. Since small rockets with low power engines will not rise over several hundred feet, an open field such as a playground, soccer or football field is adequate. At this point in your study, it is not necessary to concern yourself with high altitudes. The greatest challenge is to have the rocket achieve a perfect flight. If time permits, attempt two launches for each rocket. Remind students to be very observant and to record pertinent information about the performance of their rockets.
7. Do not launch near power lines, trees and buildings.
8. Watch for airplanes flying overhead. Wait until airplanes have passed over to launch.
9. Do not launch in rain, high winds and dry grass or weeds.

NAR MODEL ROCKETRY SAFETY CODE

- 1. Materials** - I will use only lightweight, non-metal parts for the nose, body, and fins of my rocket.
- 2. Motors** - I will use only certified, commercially-made model rocket motors, and will not tamper with these motors or use them for any purposes except those recommended by the manufacturer.
- 3. Ignition System** - I will launch my rockets with an electrical launch system and electrical motor igniters. My launch system will have a safety interlock in series with the launch switch, and will use a launch switch that returns to the "off" position when released.
- 4. Misfires** - If my rocket does not launch when I press the button of my electrical launch system, I will remove the launcher's safety interlock or disconnect its battery, and will wait 60 seconds after the last launch attempt before allowing anyone to approach the rocket.

5. **Launch Safety** - I will use a countdown before launch, and will ensure that everyone is paying attention and is a safe distance of at least 15 feet (4.6 m) away when I launch rockets with D motors or smaller, and 30 feet (9 m) when I launch larger rockets. If I am uncertain about the safety or stability of an untested rocket, I will check the stability before flight and will fly it only after warning spectators and clearing them away to a safe distance.
6. **Launcher** - I will launch my rocket from a launch rod, tower, or rail that is pointed to within 30 degrees of the vertical to ensure that the rocket flies nearly straight up, and I will use a blast deflector to prevent the motor's exhaust from hitting the ground. To prevent accidental eye injury, I will place launchers so that the end of the launch rod is above eye level or will cap the end of the rod when it is not in use.
7. **Size** - My model rocket will not weigh more than 53 ounces (1500 grams) at liftoff and will not contain more than 4.4 ounces (125 grams) of propellant or 71.9 pound-seconds (320 N-sec) of total impulse. If my model rocket weighs more than one pound (453 grams) at liftoff or has more than 4 ounces (113 grams) of propellant, I will check and comply with Federal Aviation Administration regulations before flying.
8. **Flight Safety** - I will not launch my rocket at targets, into clouds, or near airplanes, and will not put any flammable or explosive payload in my rocket.
9. **Launch Site** - I will launch my rocket outdoors, in an open area at least as large as shown in the accompanying table, and in safe weather conditions with wind speeds no greater than 20 miles per hour (32 k/h). I will ensure that there is no dry grass close to the launch pad, and that the launch site does not present risk of grass fires.

LAUNCH SITE DIMENSIONS

Installed Total Impulse (Newton-seconds)	Equivalent Motor Type	Minimum Site Dimensions (Feet) (Meters)	
0.00 - 1.25	1/4A & 1/2A	50	15
1.26 - 2.50	A	100	30
2.51 - 5.00	B	200	60
5.01 - 10.00	C	400	120
10.01 - 20.00	D	500	150
20.01 - 40.00	E	1000	300
40.01 - 80.00	F	1000	300
80.01 - 160.00	G	1000	300
160.01 - 320.00	Two G's	1500	450

10. **Recovery System** - I will use a recovery system such as a streamer or parachute in my rocket so that it returns safely and undamaged and can be flown again, and I will use only flame-resistant or fireproof recovery system wadding in my rocket.
11. **Recovery Safety** - I will not attempt to recover my rocket from power lines, tall trees, or other dangerous places.

LAUNCH SITE PREPARATIONS

Below is a description of each position that may be needed and a layout of the field to help you organize your launch day.

Range Safety Officer (RSO) - Yourself or the leader who is in charge. The RSO has the final say in all situations. The RSO watches the safety key at all times and checks the air-worthiness of all rockets.

Launch Control Officer (LSO) - The person responsible for actually firing the rocket. Control panel set-up and dismantling is also this person's responsibility.

Tracking Officer (TO) - This person is responsible for the set-up, operation and coordination of the tracking sites.

1-2 Tracking Site - These could consist of several positions at each site. Positions could include: tracking the rocket to measure its altitude, recording altitude data and a runner to communicate with the TO back at the launch pad.

Recovery Crews (RC) - Consist of several people who follow the flight, recover and return the rocket to the range head.

- | | | |
|------------------------|--------------------------|---|
| ① Tracker 1 | ⑤ Preparation Table | ⑨ Range-In-Operation Pennant (optional) |
| ② Tracker 2 | ⑥ Recovery Team | ⑩ Students-Observers |
| ③ Range Safety Officer | ⑦ Launch Control Officer | ⑪ Parking Area (optional) |
| ④ Data Recording Table | ⑧ National or Club Flag | ⑫ Launch Pad |

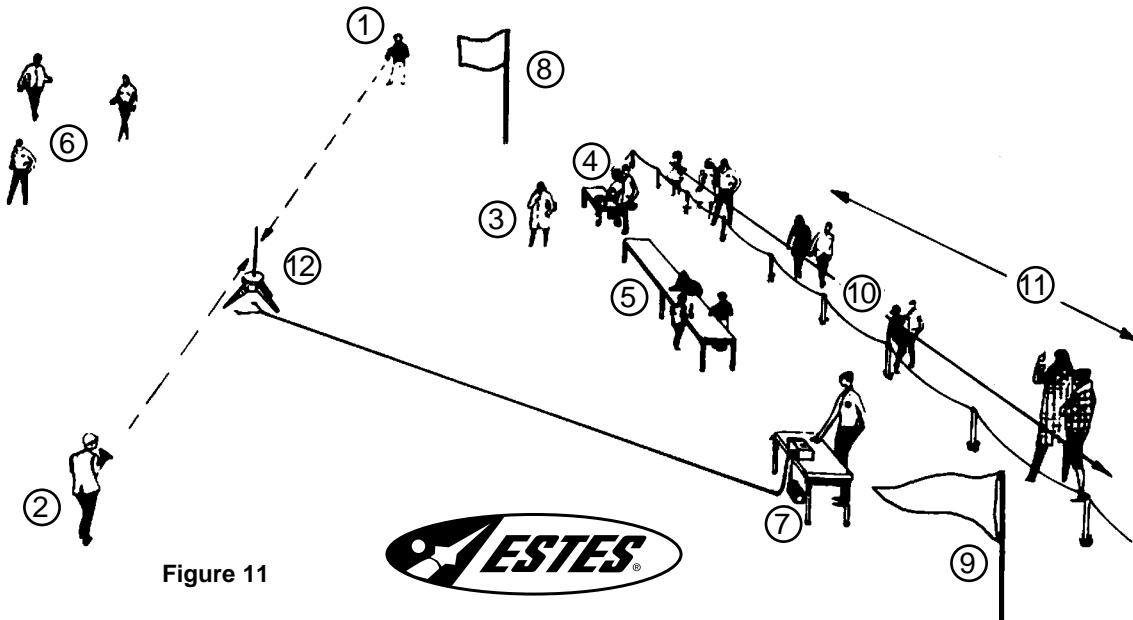

Figure 11

In addition to the above suggestions, a table could be set up for preparation of the rockets before flight with someone responsible to coordinate the flow of rockets to the pad. After the data is recorded, another person could be responsible for collecting and compiling the individual data cards into one report.

Preparing for a launch day well in advance and rehearsing the various operations prior to a school or group launch will ensure a high level of successful launches and provide a well-coordinated program that everyone will enjoy. The importance of staging a launch day has its value in stressing teamwork during the ground operations while promoting good competition during the flight portion.

Cross training your students in all of the various roles mentioned above will familiarize them with the entire launch operation and increase the level of interaction each student experiences. The possibilities of a launch day are unlimited and it is a wonderful way to bring any rocket or space unit to a conclusion.

For more detailed information, consult the Estes® Model Rocket Contest Guide (#2815) located in the “Publications” section of The Estes Educator™ Web Site (www.esteseducator.com).

F. LAWS PERTAINING TO MODEL ROCKETRY

In the United States model rocketry is regulated by the following agencies and organizations:

U.S. Department of Transportation

Rocket engines are classified for shipping and transport.

U.S. Consumer Product Safety Commission

Model rocket engines complying with certain requirements have been exempted from classification as a banned hazardous substance. Engines and/or their packaging have specific labeling and instruction requirements.

Federal Aviation Agency

Has exempted model rockets weighing 16 oz. (453 g) with engine(s) and using less than 4 oz. (113 g) of propellant from regulation.

National Fire Protection Association

Developed and adopted ANSI/NFPA 1122 Code for Model Rocketry setting standards for the safety of the activity of model rocketry. To purchase a copy of NFPA 1122 write or call: NFPA, One Batterymarch Park, Quincy, MA 02269, (800) 344-3555.

In addition, many states have adopted their own model rocketry laws and regulations.

States with additional legal regulatory requirements are:

California (effective July 1992)

- To purchase 1/4A through D engines, you must be 14 years of age or older.
- To purchase E or larger engines, you must be 18 years of age or older.
- Children as young as 12 may participate in an educational model rocketry program with adult supervision.
- Launch sites must be approved by the local fire marshal.

- The California State Fire Marshal's seal must be on all approved model rocket engines. Do not purchase engines without the seal.
- State of California regulations can be obtained from:
 CDF/Office of the State Fire Marshal
 Fire Engineering, FW Program
 P.O. Box 944246, Sacramento, CA 94244-2460

New Jersey (effective July 9, 1992)

- To purchase 1/4A through C engines, you must be 14 years of age or older.
- To purchase D or larger engines, you must be 18 years of age or older.
- Children as young as 12 may participate in an educational model rocketry program with adult supervision.
- To obtain a copy of the State of New Jersey Model Rocket Statutes 21:1C-1 through 21:1C-6 write to:
 State of New Jersey
 Department of Labor
 John Fitch Plaza
 Trenton, NJ 08625

Rhode Island

- To purchase 1/4A through C engines, you must be 14 years of age or older and have a parent's or guardian's permission.
- To purchase D or larger engines, you must be 18 years of age or older.
- To use model rocket engines, you must obtain written or verbal permission from local fire authorities to use a specific launch site.
- To obtain permits and/or a copy of the State of Rhode Island Model Rocketry Regulations Section 23.28-29, Laws of the State of Rhode Island, write to:
 Rhode Island State Fire Marshal
 24 Conway Ave., Bldg. 42
 Quonset Point-Davisville Industrial Park North, Kingstown, RI 02852
 c/o Chief of Technical Services

In Canada, model rocketry is regulated by the Canadian Bureau of Explosives. No licenses or permits are required to participate in model rocketry. However, one must be at least 12 years of age to purchase and use model rocket engines. The Canadian Model Rocketry Safety Code should be followed at all times.

For information concerning Canadian model rocketry regulations, write to:

Explosives Branch
 580 Booth Street
 Ottawa, Ontario
 K1A 0E4
 Phone (613) 943-8251
 Fax (613) 995-0480

You may obtain copies of most U.S. and state model rocketry regulations from Estes® Industries by calling (719) 372-6565 ext. 273. If you are in a country other than the U.S. or Canada, you should contact Estes® Industries for further information.

DON'T STOP NOW!!

You will find Estes® Model Rocketry to be a wonderful way to make science come to life for your students and to introduce them to rocketry - but we hope it will not stop there.

Continuing activities could include: developing more advanced experiments and rocket designs, having the students give presentations concerning the many subjects that contain model rocketry, writing reports on specific investigations that your students are conducting or other topics in space and rocket studies. The possibilities are infinite.

“THINK ESTES® FOR ALL OF YOUR MODEL ROCKET NEEDS”



ESTES® INDUSTRIES
1295 H Street
Penrose, CO 81240
800-820-0202

6/02

EST 2814